



INSTALLATION, OPERATION AND MAINTENANCE INSTRUCTIONS

HDL206 NE- Emergency Luminaires

ATEX

Important:

Please read these instructions carefully before installing or maintaining this equipment. Good electrical practices should be followed at all times and this data should be used as a guide only.

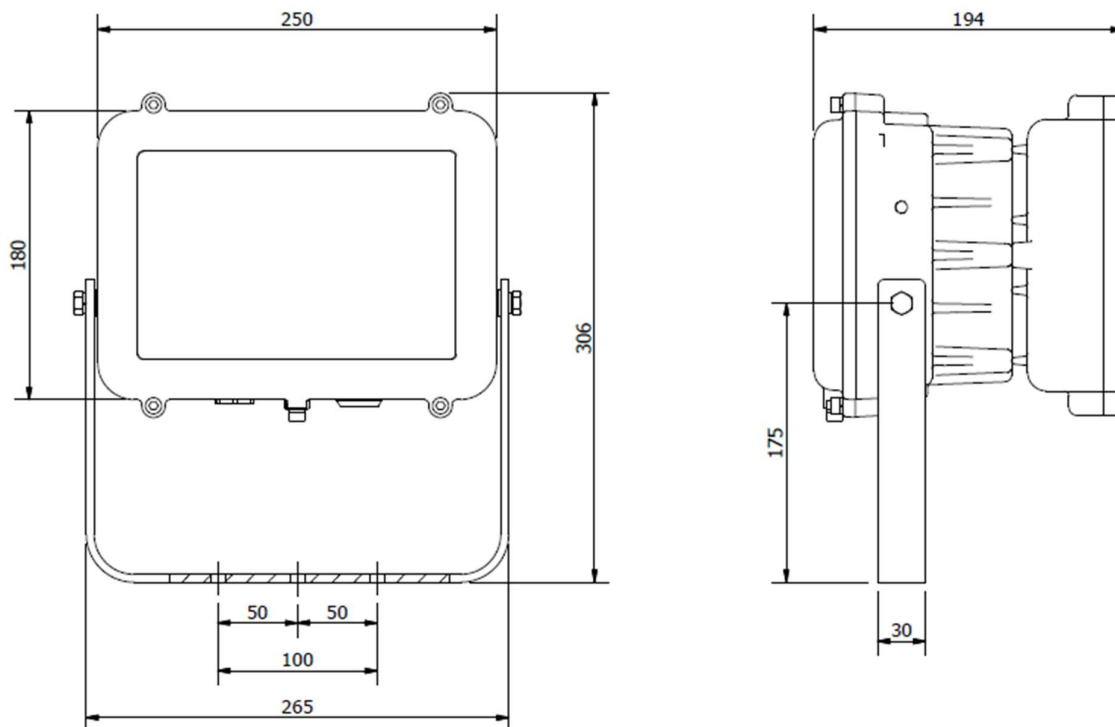

Weight 8kg

Windage – 0.05m²



Type Of Protection	Ex e mb (Increased safety,encapsulation), Ex tb (dust)	
Protection Standards	EN 60079-0, EN 60079-7, EN 60079-18, EN 60079-31	
Area Classification	Zone 2 areas to EN 60079-10-1 Zone 22 areas to EN 60079-10-2	
Installation	EN 60079-14	
Certificate	Type Examination Certificate Sira 11ATEX4314X	
Equipment Coding	HDL206NE Ex e mb IIC T4 Gc Ex tb IIIC T103°C Dc IP6X -20° ≤ Ta ≤ +50°C	for use at +55°C ambient see Specific Conditions of Use (below) No. 10.
ATEX Coding	Ⓔ II 3GD	
Ingress Protection	IP66/67	
Laser safety class	Class 1 LED product	
CE Mark	<p>The CE marking of this product applies to "The Electrical Equipment (Safety) Regulations 2006", "The Electromagnetic Compatibility Regulations 2004", the "Waste Electrical and Electronic Equipment Regulations 2006" and the "Equipment and Protective Systems intended for use in Explosive Atmospheres Regulations 1996". [This legislation is the equivalent in UK law of EU directives 2014/35/EU, 2014/30/EU, 2012/19/EU and 2014/34/EU respectively].</p> <p>The Equipment is declared to meet the provisions of the ATEX directive (2014/34/EU) by reason of the Type Examination and compliance with the Essential Health and Safety Requirements. A Reid Technical Manager</p>	

SPECIFIC CONDITIONS OF USE (denoted by X after the certificate number).

1. Except for internal wiring, not more than one single or multiple strand lead shall be connected into either side of any terminal, unless multiple conductors have been joined in a suitable manner, e.g. two conductors into a single insulated crimped boot lace ferrule.
2. Leads connected to the terminals shall be insulated for the appropriate voltage and this insulation shall extend to within 1 mm of the metal of the terminal throat.
3. When terminals in accordance with certificate Sira 01ATEX3247U are used, all terminal screws, used and unused, shall be tightened down to between 0.5 Nm and 0.7 Nm.
4. When terminals in accordance with certificate Sira 01ATEX3249U are used, all terminal screws, used and unused, shall be tightened down to between 1.2 Nm and 2 Nm.
5. When terminals in accordance with certificates Sira 01ATEX3247U and Sira 01ATEX3249U are used, they shall only be installed and wired with cable within a temperature range of -10°C to 80°C.
6. When cross-connecting combs are used on terminals to certificates Sira 01ATEX3247U and Sira 01ATEX3249U, the relevant conditions associated with those certificates shall be applied.
7. Cable entry holes shall be fitted with either an appropriately certified cable gland or appropriately certified blanking element. These shall provide and maintain a minimum enclosure ingress protection of IP66 or IP67 as appropriate.
8. If more than 8 individual LEDs are not illuminated, the LED assembly shall be replaced.
9. The supply circuit must be protected by a fuse capable of withstanding a prospective short circuit current of 1500 A.
10. The battery powered emergency versions, are suitable for an ambient temperature range of -20°C to +50°C when installed with the terminal cross-link in accordance with the manufacturer's installation instructions, which achieves a 75% output, i.e. 48 illuminated LEDs. The HDL106NE is suitable for an ambient temperature range of -20°C to +55°C when the terminal cross-link is not installed, which achieves 35% output.
11. When the Lexan polycarbonate lens is fitted, the equipment shall only be used in areas with a low risk of mechanical impact.
12. Under certain extreme circumstances, the non-metallic parts incorporated in the enclosure of this equipment may generate an ignition-capable level of electrostatic charge. Therefore, the equipment shall not be installed in a location where the external conditions are conducive to the build-up of electrostatic charge on such surfaces. In addition, the equipment shall only be cleaned with a damp cloth.



1.0 Introduction

The Chalmit HDL206NE range brings to hazardous areas the very latest in lighting technology. It is a compact light source that uses ultra bright light emitting diodes to provide light from mains power. The LEDs are maintenance free and can last up to 150,000 hours @ 25°C ambient. They are housed in an impact and corrosion resistant marine grade aluminium enclosure with a toughened glass or polycarbonate lens. The control gear is electronic with regulated lamp output. The LEDs work equally well at very low temperatures as they do at high and produce a product with very low overall power consumption.

Important:

Electrostatic Charging Hazard: Clean only with a damp cloth, when fitted with a polycarbonate lens.

LED White High Power.

Voltage ranges: 100 – 254V 50/60 Hz

Electrical Operating Data @ 100-254V 50Hz	<u>48 x LED HDL206NE</u>	<u>96 x LED HDL206NES</u>	<u>96 x LED HDL206NEE</u>	<u>144 x LED HDL206NSES</u>	<u>144 x LED HDL206NESE</u>	<u>144 x LED HDL206NEEE</u>
Power Watts	62W	113W	122W	165W	174W	184W
Current Amps	0.66 – 0.27A	1.21 – 0.48A	1.3 – 0.51A	1.76 – 0.7A	1.86 – 0.73A	2.0 – 0.77A

For lumen output photometric data can be requested.

Power Factor 0.9 minimum

Over voltage 375V

Looping The looping current rating is 12A. 4mm² terminals are standard.

Storage Luminaires are to be stored in cool dry conditions -40°C to +50°C preventing ingress of moisture and condensation. Battery packs in storage should be cycled charged/discharged/charged every 9 months, as per instructions below.

Always disconnect battery plug and socket for storage.

Any specific instructions concerning emergency luminaires must be complied with.

(Warning: Battery packs not cycled and stored for a year may not be recoverable)

'IMPORTANT NOTE FOR ALL EMERGENCY UNITS:

Please ensure encapsulated fuse provided in each emergency unit is removed from its packaging and connected between the 2 terminals marked 'BATT +'. Failure to do so will mean luminaire will not operate in emergency mode.'

PAT Testing (Insulation) 500V DC MAX for 1 min

1.0 Installation and Safety

1.1 General

There are no health hazards associated with this product whilst in normal use. However, care should be exercised during the following operations. Installation should be carried out in accordance with *EN/IEC 60079-14* or the local hazardous area code of practice, whichever is appropriate, and fitting of specified insulating material to be adhered to where a specific fire resistance rating is required. In the UK the requirements of the '*Health and Safety at Work Act*' must be met.



Handling and electrical work associated with this product to be in accordance with *the 'Manual Handling Operations Regulations'* and *'Electricity at Work Regulations, 1989'*. Your attention is drawn to the paragraphs (i) 'Electrical Supplies', (ii) 'Electrical Fault Finding and Replacement' and (iii) 'Inspection and Maintenance'. The luminaires are class 1 and should be effectively earthed. Certification details on the rating plate must be verified against the application requirements before installation.

The information in this leaflet is correct at the time of publication. The company reserves the right to make specification changes as required.

1.2 Use in Combustible Dust Atmospheres

Where the equipment is used in ignitable dust atmospheres reference must be made to the selection and installation standards in order that the equipment is used correctly. In particular this applies to the de-rating of surface temperature for use where dust clouds may be present. Dust layers should not be allowed to accumulate on the surface and good housekeeping is required for safe operation. Dust in layers has the potential to form ignitable clouds and to burn at lower temperatures.

Refer to EN 60079-10-2 & EN 60079-14 for additional details of selection and installation.

1.3 Hybrid Mixtures – Gas and Dust

Where hybrid mixtures exist as defined in EN 1127 as a potentially explosive atmosphere, consideration should be given to verifying that the maximum surface temperature of the luminaire is below the ignition temperature of the hybrid mixture.

1.4 Tools

5mm Allen Key (Hex)

Spanners for installing cable glands. Pliers, knife, wire strippers/cutters.

1.5 Emergency Duration

The luminaire is supplied set for 90 minutes emergency duration at 75% light output. This is suitable for an ambient of +50°C. This is set by factory installing a wire link between terminals marked Hi/Lo. If this cross link is removed, the luminaire will achieve 35% light output for 3 hours in emergency operation and is suitable for an ambient of +55°C.

(note: on double and triple units, this link will need to be removed in each emergency module to achieve 3 hour duration)

2.0 Electrical Supplies

The standard unit is rated for a nominal 100V-254V AC 50Hz or 60Hz. A maximum voltage variation of +6%/-6% on the nominal is expected. (The safety limit for T rating is +10%). Equipment must not be operated outside of the rated voltage of the control gear. The lamp supply is regulated therefore the light output over the supply range is constant.

3.0 LED Array & Driver

This product is fitted with LEDs that can last up to 150,000 hours @ 25°C ambient. Therefore in many applications replacement of the LED array will be unnecessary. If replacement is required ensure mains supplies are isolated before commencing work. Remove the front cover and then remove the LED array assembly.

Care must be taken when disconnecting and reconnecting wiring.

If required contact Chalmit Technical.

4.0 Mounting

Luminaires should be installed where access for maintenance is practical and in accordance with any lighting design information provided for the installation.

The fitting is supplied with an eye bolt for a safety line.

NOTE: When mounting a triple unit, the 2 outermost and the centre mounting holes must be used to secure the stirrup in place.



5.0 Cabling and Cable Glands

5.1 Cables

The maximum conductor size is 4mm². Internal earth point is provided in the main terminal block. 300/500V cable ratings are adequate and no special internal construction is necessary. The standard looping cable size is up to 4mm². The selection of cable size must be suitable for the fuse rating. Terminals are supplied with suitability for looping. Where looping is used the maximum current is 12A. Terminals are accessed by removing the front cover and LED array. For Maximum cable temperature rise refer to nameplate.

5.2 Cable Glands

The installer and user must take responsibility for the selection of cables, cable glands and seals. Two tapped cable entries are provided, one with a plug and seal suitable for permanent use, the other with a travelling plug not suitable for use in service. Sealing plugs are similarly rated and a tool must be used for their removal. Cable entries are M20x1.5. Cable glands and sealing plugs must have ATEX approval or be certified to EN60079-0. For installation outside the EU suitable cable glands in accordance with IEC 60079-0 will meet the technical requirements.

The cable and gland assembly when installed must maintain the ingress protection rating of the luminaire. The cable glands must be suitable for the application. Where brass cable glands are used in a corrosive environment, cadmium or nickel plating should be used.

6.0 Inspection and maintenance

Visual inspection should be carried out at a minimum of 12 monthly intervals and more frequently if conditions are severe; refer to EN 60079-17.

7.0 Electrical fault finding and replacement

Any fault finding must be done by a competent electrician with the luminaire isolated and, if carried out with the luminaire in place, under a permit to work. Fault finding is by substitution with known good components.

8.0 Routine Maintenance

Visual tests and checks should be carried out at intervals described by the appropriate regulations, EN/IEC 60079-17, and should include the following:

Check that the LEDs are working.

Check for mechanical damage/corrosion.

Check for loose connections including earthing.

Check for undue accumulations of dust or dirt.

Verification of tightness of fixing, glands, blanking plugs etc. *Torque Values- Stirrup mounting point: 10Nm, Aluminium/Glass Diffuser fixing screws: 4Nm, Polycarbonate Diffuser fixing screws: 1.5 - 2Nm.*

Check for unauthorised modifications.

Check condition of enclosure gasket and fastenings.

Check for any accumulation of moisture.

Periodic inspection of the enclosure seal should be carried out to ensure that the seal is sound.

If the luminaire has been subject to abnormal conditions, for example, severe mechanical impact or chemical spillage, it must be de-energised until it has been inspected by an authorised and competent person. If in doubt, the unit should be returned to Chalmit for examination and, if necessary, replacement.

Before re-assembling, all connections should be checked and any damaged cable replaced.

8.1 Checking of Battery separately

If the battery is to be checked separately, it should be charged using a **constant current charger** at 200/400mA for 30/15 hours for the 7Ah. Discharge measurement is not easy as the current is proportional to the voltage for resistance loads, so it has to be averaged. Discharge the battery at 1 to 2A and multiply current by time. Do not discharge below 1 volt per cell, which is 5V. The capacity should be 75% or more of normal.



9.0 Disposal of Material

The unit is mainly made from incombustible materials. The control gear contains plastic resin and electronic components. All electrical components may give off noxious fumes if incinerated. Take care to render these fumes harmless or avoid inhalation. Any local regulations concerning disposal must be complied with. Any disposal must satisfy the requirements of the WEEE directive [2012/19/EU] and therefore must not be treated as commercial waste.



To comply with the Waste Electrical and Electronic Equipment directive 2012/19/EU the apparatus cannot be classified as commercial waste and as such must be disposed of or recycled in such a manner as to reduce the environmental impact.

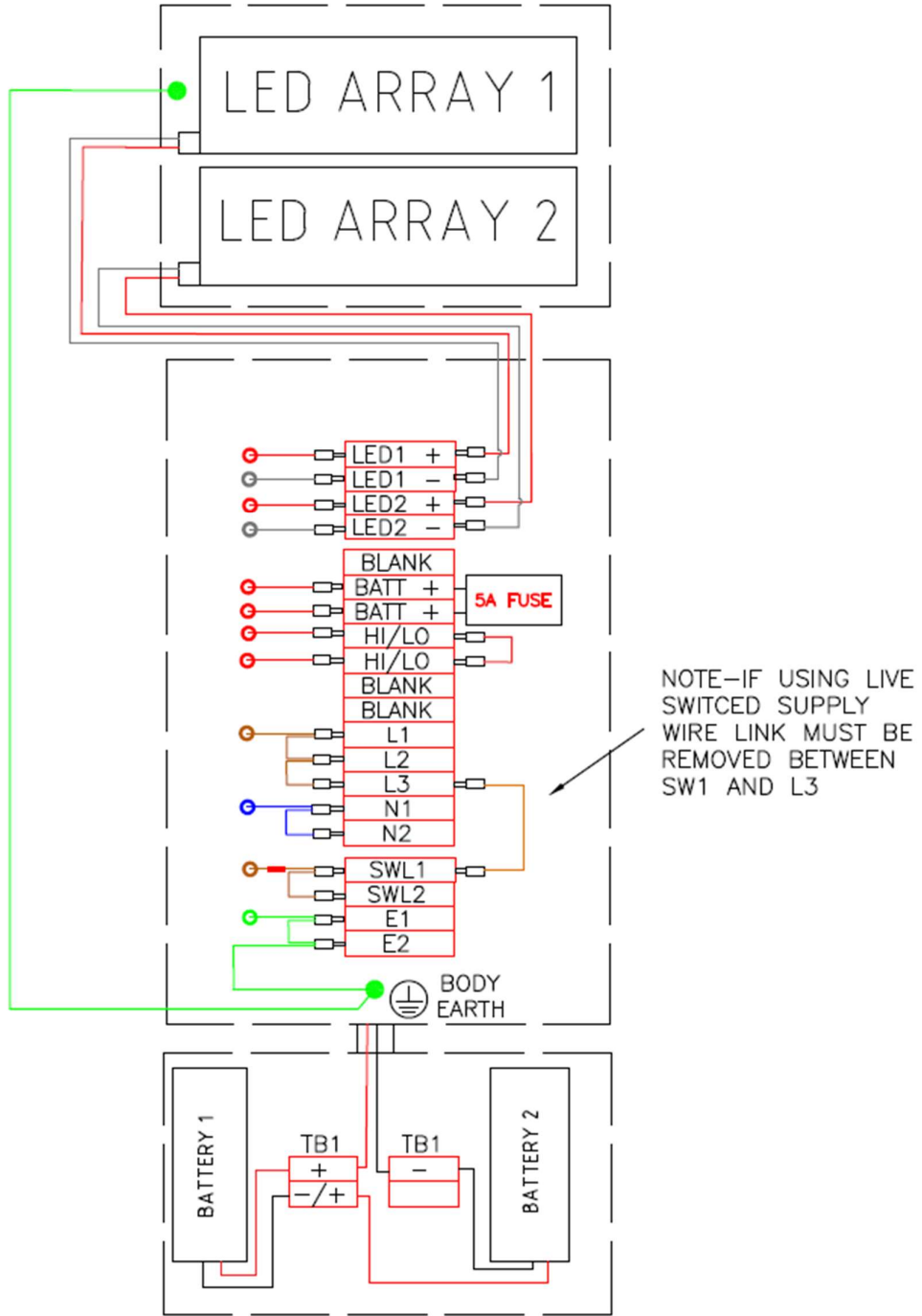



Chalmit Lighting is a leading supplier of Hazardous Area lighting products

	<p><u>CHALMIT LIGHTING</u> PO Box 5575 Glasgow, G52 9AP Scotland</p>	
<p>Telephone: +44 (0) 141 882 5555 Fax: +44 (0) 141 883 3704 Email: info@chalmit.com Web: www.chalmit.com</p>	<p>Registered No: 669157 Registered Office: Cannon Place 78 Cannon Street London EC4N 6AF UK</p>	

For technical support, please contact: techsupport@chalmit.com

Note: Chalmit Lighting reserves the right to amend characteristics of our products and all data is for guidance only.



	EU-Declaration of conformity		
	UE-Déclaration de conformité		
	EU-Konformitätserklärung		
Manufacturer	Chalmit	Address	388 Hillington Road, Glasgow. G52 4BL Scotland UK
Product	HDL 206 Modular Floodlight/Bulkhead		
Type Examination Certificate	Sira 11ATEX4314X		
Notified Body	CSA Group Netherlands B.V. 2813		
ATEX Coding	II 3 GD	ATEX Classification	Group II Category 3 GD
Equipment Coding:			
HDL206NE 100V to 254V 50/60Hz	Ex e mb IIC T4 Gc , Ex tb IIIC T103°C Dc IP6X -20°C ≤ Ta ≤ +50°C		
Ingress Protection	IP66/67		
The technical basis, with respect to equivalence of			
La base technique, en ce qui concerne l'équivalence de			
Die technische Grundlage hinsichtlich der Normen			
Protection Standards EN 60079-0, EN 60079-7, EN 60079-18, EN 60079-31.			
Area Classification EN 60079-10-1 and EN 60079-10-2			
of compliance with the EHSRs is valid as there are no changes which materially affect the state of technological progress of the product.			
en conformité avec les EESS est valide puisqu'il n'y a aucun changement qui affecte matériellement l'état de l'évolution technologique du produit.			
zur Erfüllung der GSGA ist gegeben, da keine Änderungen erfolgt sind, die einen Einfluss auf den technischen Stand des Produkts haben.			
Terms of the directive:		Standard & Date Certified to	Standards Date Declared to
Prescription de la directive:		Standard & date certifiée à	Normes date Déclaré
Bestimmungen der Richtlinie:		Standard & Datum Zertifiziert nach	Standards Datum erklärt
2014/34/EU	Equipment and protective systems intended for use in potentially explosive atmospheres.	EN 60079-0: 2012	2018
		EN 60079-7: 2007	2015
2014/34/UE	Appareils et les systèmes de protection destinés à être utilisés en atmosphères potentiellement explosibles.	EN 60079-18: 2009	2015
		EN 60079-31: 2009	2014
2014/34/EU	Geräte und Schutzsysteme zur bestimmungsgemäßen Verwendung in explosionsfähigen Bereichen.		
2014/30/EU	Electromagnetic compatibility	EN 55015 : 2019	
2014/30/UE	Compatibilité électromagnétique	EN 61547 : 2009	
2014/30/EU	Elektromagnetische Verträglichkeit	EN 61000-3-2 : 2019	
		EN 61000-4-3 : 2020	
2014/35/EU	Low voltage equipment	EN 60598-1 : 2015	
2014/35/UE	Équipements électriques à bas voltage	EN 60598-2-5 : 2015	
2014/35/EU	Niederspannungsgeräte / -systeme	EN60598-2-22:2014	
		EN 60529 : 1992+A2:2013	
2012/19/EU	Waste of electrical and electronic equipment		
2012/19/UE	Déchets d'équipements électriques et électroniques		
2012/19/EU	Entsorgung der elektrischen und elektronischen Geräte / Systeme		
2011/65/EU	RoHS II Directive		



On behalf of the Chalmit, I declare that, on the date the equipment accompanied by this declaration is placed on the market, the equipment conforms to all technical and regulatory requirements of the above listed directives.

En tant que représentant du fabricant Chalmit, je déclare qu'à la date où les équipements accompagnant cette déclaration sont mis sur le marché, ceux-ci sont conformes à toutes les dispositions réglementaires et techniques des directives énumérées ci-dessus.

Hiermit bestätige ich, im Namen von Chalmit, dass am Tag der Lieferung des Produkts/der Produkte zusammen mit dieser Erklärung das Gerät/die Geräte alle technischen und regulativen Anforderungen der oben aufgeführten Direktiven erfüllt.

Name and Date Andrew Reid 09/11/2023
 Nom et Date
 Name und Datum

Technical Manager
 Directeur technique
 Technischer Leiter

A handwritten signature in black ink, appearing to be "AR", written over a faint grid background.

Quality Assurance Notification by:

**SGS Fimko
 OY**

Quality Management System Accreditation:

ISO 9001

Notification d'assurance qualité par:
 Qualitätssicherungsnotifikation durch:

0598

Système de Management Qualité Accréditation:
 Qualitätsmanagementsystem Akkreditierung:
 Environmental Management System.
 Système de gestion de l'environnement.
 Umwelt kontroll system.
Certificate No./Certificat N°/Zertifikat Nr.

ISO 14001
 by/par/durch
Lloyd's Register
LRQ 4005876